



# CUB SCOUTS 2017



## ***Soap Box Derby***

**Saturday, July 8<sup>th</sup>**

Join us in El Segundo for Racing, Food, Music, and Fun!

A Tradition Organized by Pack 968 Since 1981

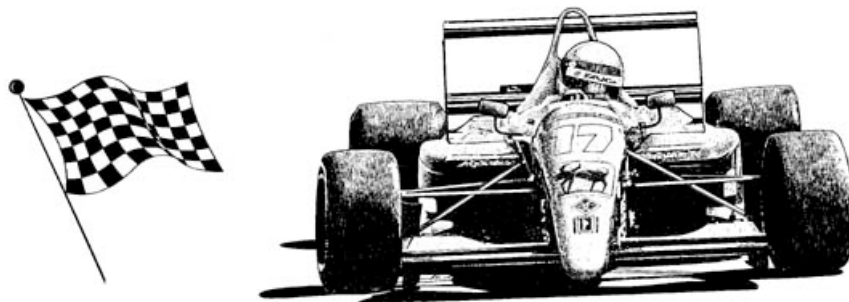

For information: Ron Campbell (310) 490-2855  
Email: [roncampbellpack968@gmail.com](mailto:roncampbellpack968@gmail.com)  
When: Saturday, July 8, 2017  
Where: El Segundo Scout House, 325 E. Grand Ave., El Segundo, CA 90245

**Racing Teams May Arrive for Pit Row Set-up at 9:00am**

**Registration, Check-in and Inspection: 9:30am - 10:30am (Mandatory)**

**Opening Ceremony & Racing Starts at 11:00am**

**Open to ALL Cub Scouts**

# 2017 PACIFICA DISTRICT SOAP BOX DERBY RULES

**Some Rules and Requirements have changed. Please read carefully.**

## Race Rules and Team Requirements:

- For insurance reasons, drivers must be registered Cub Scouts: Wolf (completed first grade) to Webelos (completed fourth grade) No fifth-grade graduated Webelos moving into Boy Scouts.
- **IMPORTANT:** Tour Plan **must** be filed for each participating unit and brought to registration table
- Racing will be grouped by Scout rank as follows: Wolf, Bear, Webelos, Arrow Of Light (Scouts race at their NEW rank as held after spring graduations)
- Teams with drivers of mixed scout ranks must race in highest ranked group
- Maximum number of registered drivers per team is three (3)
- **IMPORTANT:** A completed and signed Talent Release Form and Permission Slip / Medical Release Form must be filed (in advance or at registration) for EACH driver on your team.
- **IMPORTANT:** Each team must have a minimum of two registered adult crew members (it is highly recommended that you have more than two)
- **IMPORTANT:** Two (2) registered adult crew members must be present every time your team races (one at the start line, one at the finish line) in order for the team to race
- Only registered adult crew members will be allowed into the starting gate, finish line, and post-race staging areas
- **IMPORTANT:** Cars, drivers and adult crew members can only belong to a single racing team.
- No sharing of cars between race teams
- **IMPORTANT:** Seatbelt is required in order for car to pass inspection and race
- **IMPORTANT:** Helmet (bike, motorcycle or football helmets OK) is required for each driver
- Drivers must be familiar with & able to operate all car controls (practice in steering & braking is highly recommended)
- Braking mechanism must be repeatable by the driver. No weight-based or “anchor-type” single-use braking systems are allowed. If you are not sure about your braking system, please ask before race day.
- No practice racing or trial runs on race day
- Gravity racing only. No pushing off. No power/drive/assist devices allowed.
- Cars are deemed to have crossed the finish line when the front wheels completely cross the line
- **IMPORTANT:** Car and driver racing only. “Added Weight” makes racing more dangerous and is not allowed.
- Each car will race a total of three (3) times. Official race time will be scored and recorded by Race Officials for use in determining “Fastest Run” and “Fastest All Around” awards.
- “Fastest Run” will be awarded to the DRIVER at each rank that records the fastest single run down the track
- “Fastest All Around” will be awarded to the CAR at each rank that records the fastest combined time for 3 runs down the track
- Lane Racing: Touching the centerline, on-course safety barricades, curb, or interfering with the other car in any way during the race will result in a DNF (did not finish) disqualification. Cars with a DNF disqualification are not eligible for the “Fastest All Around” award.
- Keep all drivers close to your car - race teams not ready to race after the third start call may be required to forfeit that race at the discretion of the Race Officials
- Decisions of the Race Officials are final
- Your racing team is responsible for returning your car to the Starting Pit during designated times
- **IMPORTANT: Maximum capacity for the event is 53 cars (First come, first served)**
- **REGISTER EARLY TO SAVE MONEY AND SECURE YOUR SPOT**

# 2017 PACIFICA DISTRICT SOAP BOX DERBY RULES (continued)

## Car Specifications and Requirements:

- Maximum Overall Length                    78 inches
  - Maximum Wheel Base                        63 inches
  - Minimum Wheel Track Width                30 inches
  - Maximum Overall Width                      36 inches
- 
- Each car must have an attached or incorporated seat and fixed backrest allowing driver to sit upright with feet forward (no head-first or laying-down driving positions)
  - A safety belt must securely restrain driver, and must be securely attached to car frame
  - The car frame must be constructed from quality 2 x 6 wood and the axle supports from quality 2 x 4 wood (or equivalent material and design to provide strength and safety for the drivers)
  - No metal frame and/or body cars are allowed
  - Axles must be fastened securely to axle support - axles must be fixed and must not turn or rotate
  - Steering shall be done with the feet and/or with the hands holding a rope or mechanical steering device attached securely to the front axle support
  - To safely limit turning radius, the maximum axel swing allowed is 2<sup>5/8</sup>” measured from the center of the axel (straight line racing requires only minor steering correction)
  - An effective brake must be installed on the car, and must be easily operated while steering the car – brakes that drag on the road surface **MUST** be faced with rubber (old tire tread works great)
  - Braking mechanism must be repeatable by the driver. No weight-based or “anchor-type” single-use braking systems are allowed. If you are not sure about your braking system, please ask before race day.
  - Maximum wheel diameter is 12”
  - All wheels must have solid rubber tires
  - **IMPORTANT:** Wheels shall have plain sleeves or bushings only - **No ball, roller, needle, etc. wheel bearings will be allowed**
  - **IMPORTANT:** Race teams will be required to remove wheels for inspection of bushings on race day (bring appropriate tools)
  - **IMPORTANT:** All components of the car must contribute to the frame, function, or safety features of the car. Any superfluous or decorative elements will only be allowed at the discretion of Race Officials. Any components of the car deemed to be “Added Weight” by Race Officials must be removed in order for the car to pass inspection and race.

**NO MODIFICATIONS ARE ALLOWED AFTER ENTRY HAS BEEN INSPECTED;  
MODIFICATIONS AFTER INSPECTION, INCLUDING REMOVING WHEELS OR  
ADDITION OF WEIGHT WILL RESULT IN DISQUALIFICATION**

We reserve the right to disqualify any car based upon safety and/or design  
Please be Trustworthy Scouters with the construction of your race cars!

**Be sure to register in advance and arrive early.  
Registration will close to walk-ins when racing all spots are all filled.**

# 2017 PACIFICA DISTRICT SOAP BOX DERBY

## CAR REGISTRATION FORM (complete one form PER CAR)

Mail Pre-Registration in advance to:

**Cub Scout Pack 968, c/o Ron Campbell, 531 Main St #968, El Segundo, CA 90245**

Cost: Pre-Registration: \$75 per CAR (received on or before July 1<sup>st</sup>)

Late/Race Day Registration: \$90 per CAR

Registration fees cover event costs and include a 2017 Soap Box Derby patch for each registered driver

PLEASE MAKE CHECKS PAYABLE TO: *Cub Scout Pack 968*

RANK (circle one):            WOLF            BEAR            WEBELOS            ARROW OF LIGHT

REGISTRATION FEE (Includes Free Patch for Each Registered Driver)

(\$75 before July 1<sup>st</sup> / \$90 after July 1<sup>st</sup>)

\$ \_\_\_\_\_

LIMITED SUPPLY OF 2017 SOAP BOX DERBY T-SHIRTS & ADDITIONAL PATCHES  
WILL BE AVAILABLE DURING CHECK-IN ON RACE DAY

TOTAL DUE (Circle One: Cash / Check# \_\_\_\_\_)

\$ \_\_\_\_\_

PACK # \_\_\_\_\_ DEN # \_\_\_\_\_ CONTACT NAME \_\_\_\_\_

ADDRESS \_\_\_\_\_

PHONE \_\_\_\_\_ EMAIL \_\_\_\_\_

CAR/TEAM NAME \_\_\_\_\_

DRIVER #1 NAME: \_\_\_\_\_ RANK: \_\_\_\_\_ (MANDATORY)

DRIVER #2 NAME: \_\_\_\_\_ RANK: \_\_\_\_\_ (OPTIONAL)

DRIVER #3 NAME: \_\_\_\_\_ RANK: \_\_\_\_\_ (OPTIONAL)

ADULT CREW MEMBER NAME: \_\_\_\_\_ (MANDATORY)

ADULT CREW MEMBER NAME: \_\_\_\_\_ (MANDATORY)

ADULT CREW MEMBER NAME: \_\_\_\_\_ (OPTIONAL)

ADULT CREW MEMBER NAME: \_\_\_\_\_ (OPTIONAL)

I have read the Pacifica District Soap Box Derby rules, including the specification requirements, and understand that if our car does not pass inspection, it may be disqualified from participating.

Signed: \_\_\_\_\_

---

(For Official Use)

Car Number: \_\_\_\_\_

Passed Inspection: \_\_\_\_\_

# TALENT RELEASE

I hereby assign and grant to the Los Angeles Area Council - Boy Scouts of America the right and permission to use and publish the photographs/film/video tapes/electronic representations and/or sound recordings made of me this date by the Los Angeles Area Council - Boy Scouts of America, and I hereby release the Los Angeles Area Council - Boy Scouts of America from any and all liability from such use and publication.

I hereby authorize the reproduction, sale, copyright, exhibit, broadcast, electronic, storage, and/or distribution of said photographs/film/video tapes/electronic representations and/or sound recordings without limitation at the discretion of the Los Angeles Area Council - Boy Scouts of America and I specifically waive any right to any compensation I may have for the foregoing.

Name: \_\_\_\_\_

Address: \_\_\_\_\_

City: \_\_\_\_\_

State: \_\_\_\_\_

Zip: \_\_\_\_\_

Phone Number: (\_\_\_\_\_) \_\_\_\_\_ - \_\_\_\_\_

District: \_\_\_\_\_ Unit Number: \_\_\_\_\_

Signed: \_\_\_\_\_ Date: \_\_\_\_\_

Guardian: \_\_\_\_\_

Witness: \_\_\_\_\_

*(if subject is younger than 18)*

Permission Slip & Medical Release Form

My child, \_\_\_\_\_, has my permission to attend and participate in the Pacifica District Soap Box Derby with Pack \_\_\_\_\_ on July 8<sup>th</sup>, 2017.

I understand he will be going to El Segundo, CA.

I understand that participating in the above activity offered through the Los Angeles Area Council, Boy Scouts of America, involves a certain degree of risk. I have carefully considered the risk involved and have given my (son/daughter), my consent to participate in this activity.

In case of emergency, I can be reached at: \_\_\_\_\_

If I cannot be reached, please contact \_\_\_\_\_ at \_\_\_\_\_

Signed: \_\_\_\_\_ Date: \_\_\_\_\_

Parent's full name (please print): \_\_\_\_\_

Scout's full name: \_\_\_\_\_ Phone: \_\_\_\_\_

Scout's Address: \_\_\_\_\_

---

**AUTHORIZATION AND CONSENT TO TREAT A MINOR**  
Pursuant to California Civil Code Section 25.8

The undersigned do hereby authorize Leaders of Pack \_\_\_\_\_ or such substitute as he/she/they may designate as agent for the undersigned to consent to any x-ray examination, anesthetic, medical, dental or surgical diagnosis or treatment and hospital care for the above minor which is deemed advisable and to be rendered under the general or special supervision of any physician and surgeon, licensed under the Provision of Medicine Practice Act, whether it be rendered at the office of said physician or dentist, at a hospital, Scout Camp or elsewhere.

The authorization will remain effective while the above minor is en route to or from or involved or participating in any Boy Scout/Cub Scout program or activity of the Los Angeles Area Council, Boy Scouts of America, unless revoked in writing by the undersigned and delivered to the aforesaid agent.

Date \_\_\_\_\_ Signature \_\_\_\_\_

Medical Insurer: \_\_\_\_\_ Medical ID: \_\_\_\_\_

# 2017 PACIFICA DISTRICT SOAP BOX DERBY

## PROJECTED SCHEDULE

(Subject to Race Day Changes)

Street Closed	8:00 am
Pit Row Opens	9:00 am
Registration/Check-In (Mandatory for all Race Teams)	9:30 am - 10:30 am
Car Inspection (Mandatory for all Race Teams)	9:40 am - 11:00 am
Opening Ceremony	11:10 am
Racing Begins (See Posted Schedule on Race Day for Racing Heat Times)	11:30 pm
Racing Ends	3:30 pm
Awards Presentation	3:45 pm
Clean Up	4:00 pm – 5:00 pm
Grand Avenue Re-opened	5:00 pm

# CAR CONSTRUCTION SUGGESTIONS

## General

1. This race evolved in El Segundo over the decades and has grown from a local event to a District event. It has no actual affiliation with the International Soap Box Derby. Certain rules may seem somewhat odd (e.g., “no wheel bearings”), but these restrictions limit the technology, cost, and speed to reasonable levels. Safety and fun are the two most important reasons for the success of the event.
2. A team of three Cubs is the right size for a one-car effort, both in terms of the cost of building the car and racing opportunities (all cars will get three runs down the hill). Larger Dens will want to consider building multiple cars. Think of the car as an investment in a multi-year activity that your Cubs can race each summer throughout their Cubbing career. Each year, your car can be improved upon (talk to the veterans about speed tips) and become faster and more competitive. The biggest investment in time and money is the first year.

## Car Construction

1. The official Soap Box Derby wheels are highly recommended. Axles can be made from  $\frac{1}{2}$  inch or larger steel rod or stock. Contact a local (small) machine shop to help with the axles and bushings; they may donate their time if you tell them it is for Cubs. Bushings can be made of many materials (steel, brass, plastic, etc.). Any type of lubricant is allowed (oil, graphite, etc.).
2. A steering approach has evolved that younger Cubs feel more comfortable with than the older rope/feet method: the tiller (see illustration). The handle bar or tiller is made from  $\frac{1}{2}$  or  $\frac{5}{8}$  inch electrical conduit, bent to the shape shown. It is attached to the front axle 2 x 4 with carriage bolts; a wood dowel inserted into the conduit will keep the bolt from crushing the conduit. This device is recommended for younger Cubs.

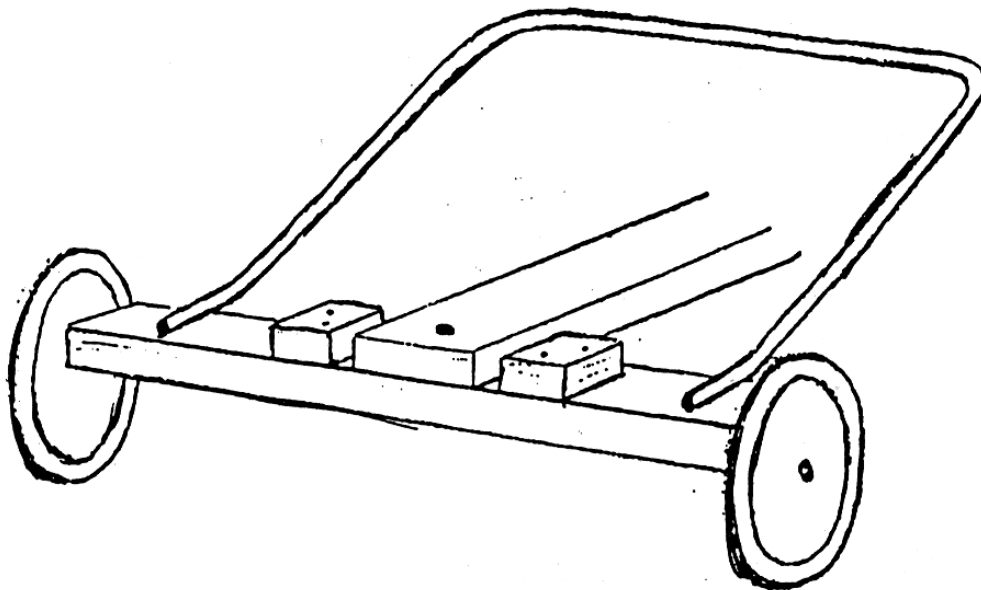



# Suggested Pacifica District Soap Box Derby Car

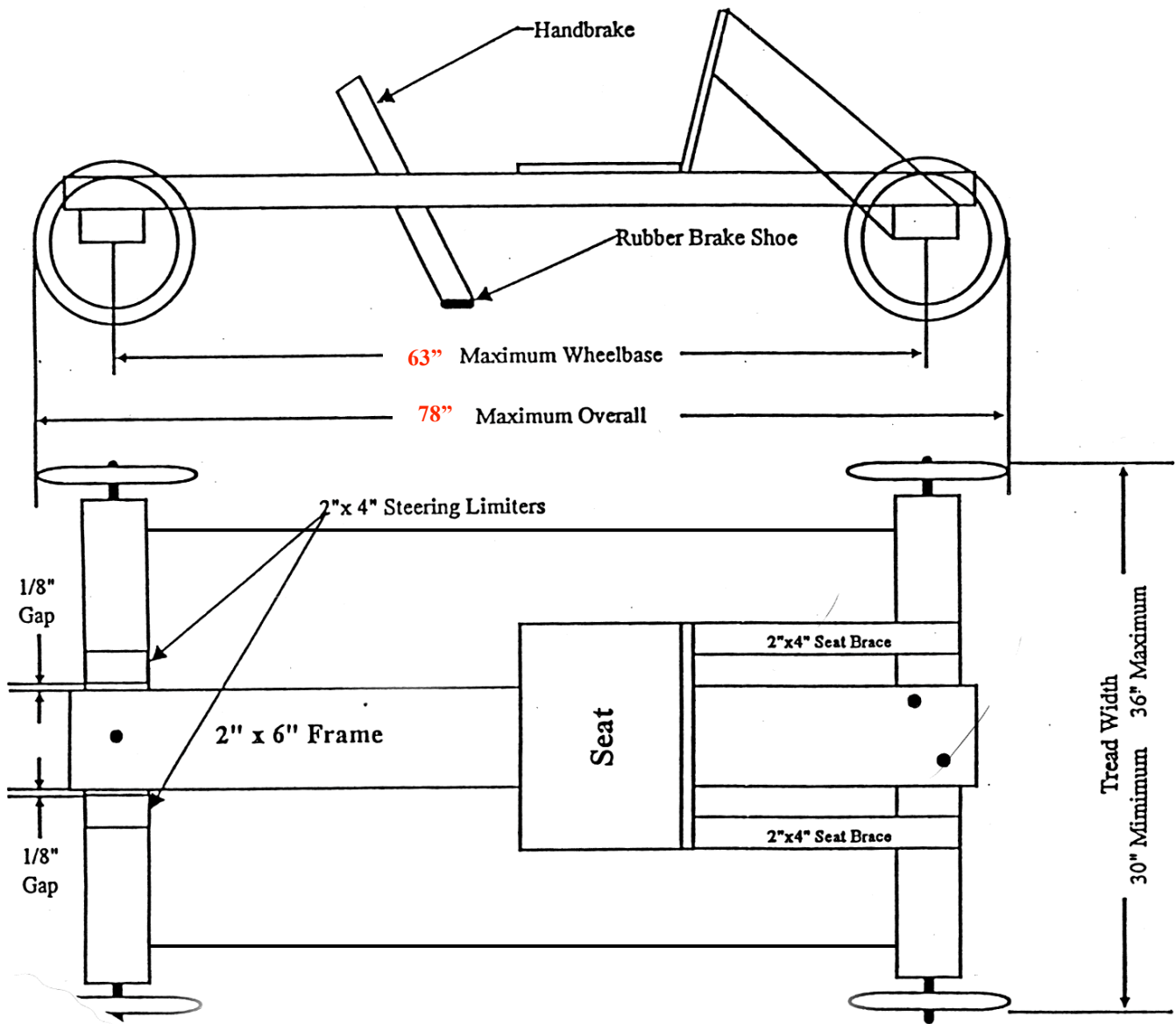

Washer and Cotter Pin

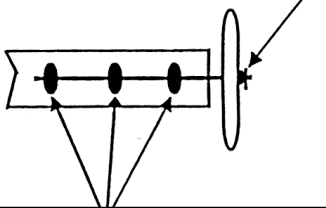

Fasten axle to axle support with J-bolts or Electrical Conduit Clamps so axle cannot turn.

Maximum wheel size is 12" diameter. Use sleeve or graphite bushings.

**Do not use ball or roller bearings...**

Fasten axle to axle support with electric conduit clamps or J-bolts. The axles must be fixed so they can't turn.

A seat belt is passed through slots cut in the seat back and bolted to the frame behind the seat.

A rope or other device is attached securely to the front axle support for steering.

**NOTE:**

Car may be imaginatively festooned by adding custom bodywork, exhaust pipes, etc., provided the basic dimensions and material specifications shown here are adhered to. **Cars lacking the materials, running gear, and safety equipment equivalent to that shown here will not be permitted to run.**

# OFFICIAL SOAP BOX DERBY Z-GLASS WHEELS

# DUPONT ZYTEL NYLON RIM

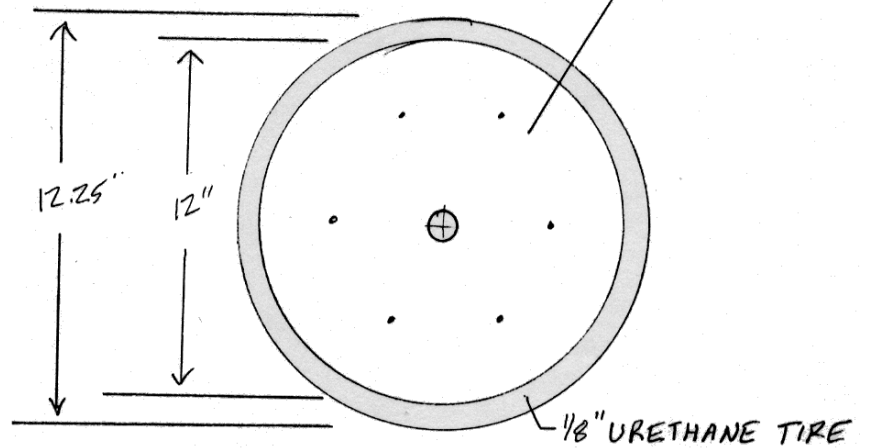
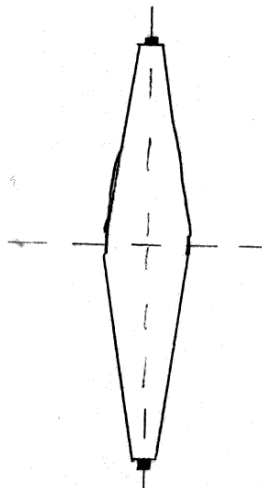

## HUB DIMENSIONS (not to scale)

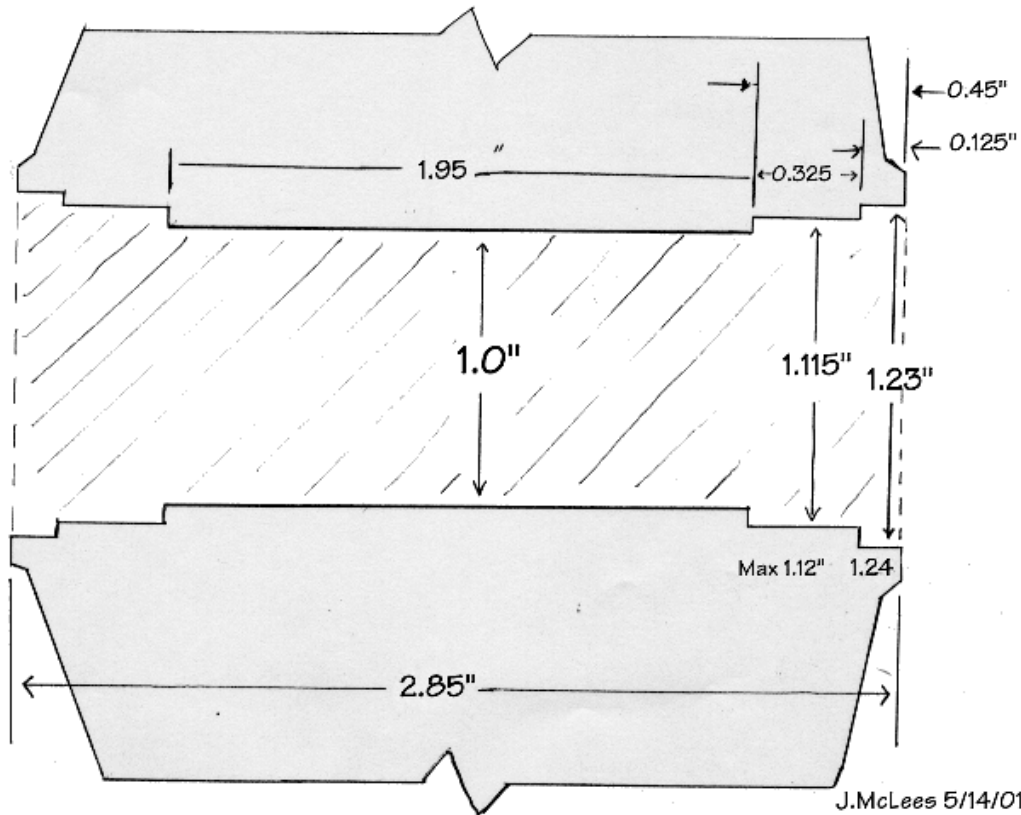

**To Order Call *International Soap Box Derby, Inc.* (330) 733-8723**  
**Or order online at [www.aasbd.com](http://www.aasbd.com) Cost (approx): \$100.00 plus shipping**

## Soap Box Derby - Suggested Parts List for 60" max length car

### Wood Parts

<b>2 x 4</b>	Rear Axle	31.5 "	This may vary with The type of wheel used
	Front Axle	31.5 "	
	Seat Brace	20.0 "	figure about 10 feet
	Seat Brace	20.0 "	
	Limiter	3.50 "	
	Limiter	3.50 "	
<b>Total</b>	<b>110.0 "</b>		
<b>2 x 6</b>	Frame	51.5 "	With 12" wheels
	Frame	53.5 "	With 10" wheels
	<b>Total</b>		figure about 5 feet
<b>2 x 2</b>	Brake	20.0 "	figure about 2 feet
<b>½ " plywood</b>	Seat back	12 x 14 "	Scrap wood
	Seat bottom	12 x 14 "	

### Hardware

Qty	Part Name	Use
4	10" or 12" diameter narrow wheels *	
2	½" diameter steel rod 36" long	axle
8	½" electrical conduit clamps	axle
16	#8 x 1" round head wood screws	axle
18	½" washers	wheels
1	½" x 4" bolt (hex)	front pivot
1	½" nut	front pivot
1	5/16" x 4" lag screw	brake
2	5/16" x 4" bolts (hex)	rear axle
3	5/16" nuts	rear axle
1	5/16" x 2 ½" bolt (hex)	seat belt
7	5/16" washers	rear axle
10	#8 x 2" round head wood screws	seat
4	#8 x 2 ½" round head wood screws	seat
4	¼" x 3 ½" bolts (hex)	limiters
4	¼" nuts	limiters
8	¼" washers	limiters

\* optional, but recommended - Official Soap Box Derby Z-Glas wheels from  
International Soap Box Derby, Inc., P.O. Box 7225, Akron, OH 44306-7225  
Phone [330] 733-8723 or order online at [www.aasbd.com](http://www.aasbd.com)  
(these wheels come with bearings which must be replaced with bushings)